

SMS ASSEMBLY AND INSTALL INSTRUCTIONS FOR YOUR LIGHT SHROUD

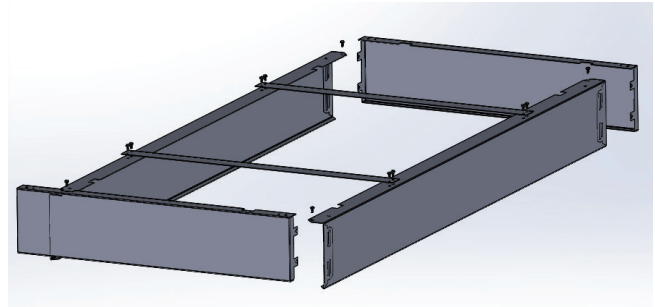

STEP 1.

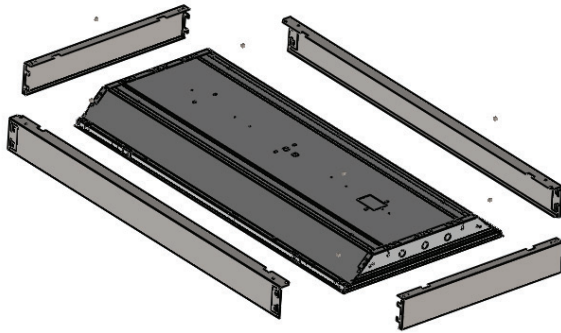
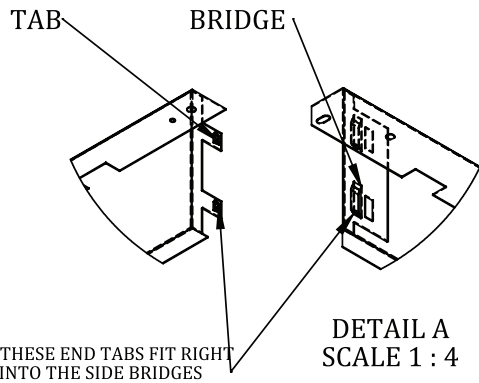
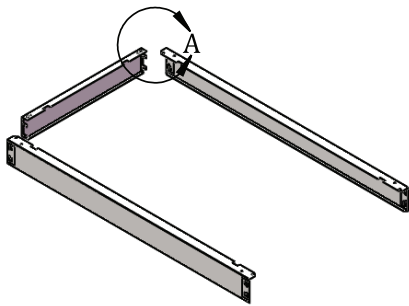

STEP 2.

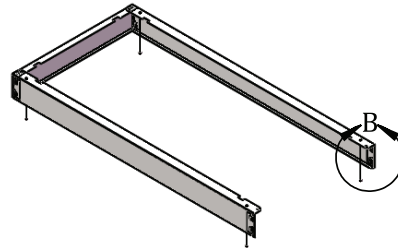

DETAIL B
SCALE 1 : 8

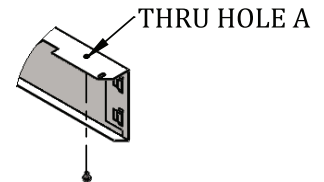

1. USING (X2) SIDE SHROUDS AND (X1) END SHROUD, ALIGN THE TABS ON THE END SHROUD WITH THE BRIDGES ON THE SIDE SHROUDS AND PRESS UNTIL THE TABS SNAP INTO PLACE.
2. FASTEN PARTIALLY ASSEMBLED SHROUD TO CEILING BY USING (X4) MOLLIES WITH HOLES MARKED "A", IN "DETAIL B".
3. TWO (2) SAFETY STRAPS INCLUDED FOR STRUCTURAL RIGIDITY.

STEP 3.

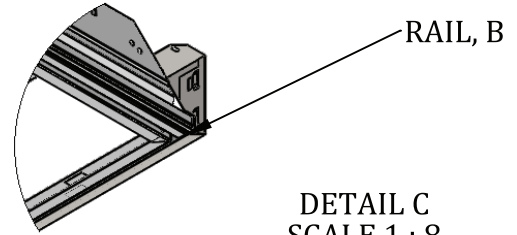
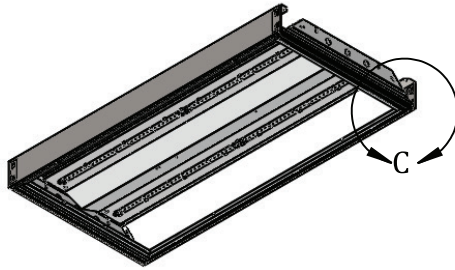

DETAIL C
SCALE 1 : 8

1. SLIDE FIXTURE INTO SHROUD ON "RAIL B", SHOWN IN "DETAIL C".
2. ATTACH REMAINING (X1) END SHROUD BY REPEATING STEP 1

STEP 4.

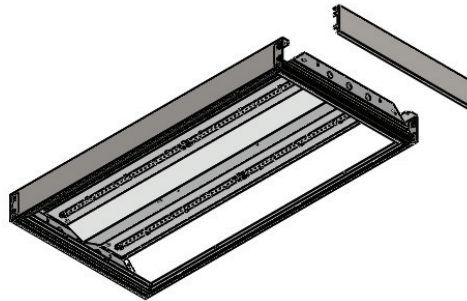

ORDERING INFORMATION

Example: SMS14 or SMSP22

SERIES	SIZE	
SMS	14	1'x4'
	22	2'x2'
	24	2'x4'

**For Low Profile Flat Panel
See Options Below:**

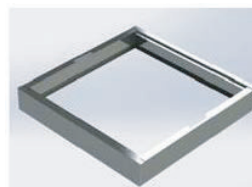

Shroud Dimensions:

- SMSFP22 - (23.7"W x 23.7"L x
- SMSFP14 - (11.7"W x 47.7"L x
- SMSFP24 - (23.7"W x 47.7"L x