

AIRCRAFT CABLE SUSPENSION

Applications

Lighting Products, Mechanical, & HVAC

Features

Looping Gripper securely locks aircraft cable in a loop, & allows for quick tool-less adjustment

Material

Brass, with Steel Ball Bearings

Finish

Bright Nickel Plated

Cable Dimension

Accepts aircraft cable diameter in inches:

X 1/16" X 3/64"

Safe Working Load at 5:1 Safety Factor

Specifications (US pounds) for 7x7 galvanized cable

1/16" Cable: 67 lbs.

3/64" Cable: 40 lbs.

Cable Adjustment

Relieve load from cable, press plunger, & adjust cable height. Release plunger and Looping Gripper locks the cable.

Installation Notes

Looping Gripper must maintain a minimum 2 inch distance from all suspended objects support structures.

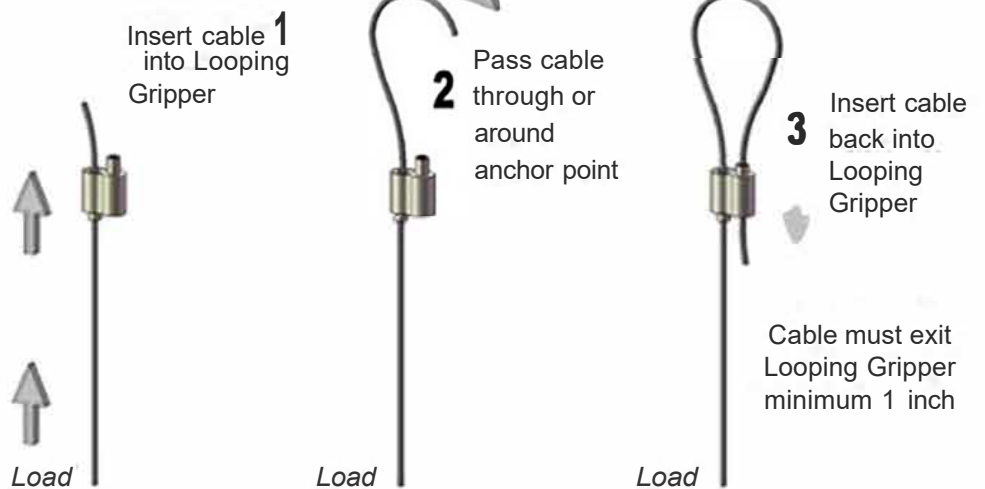
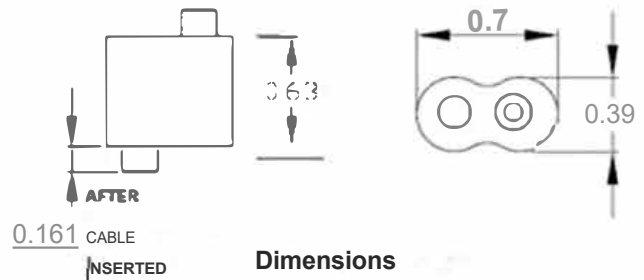
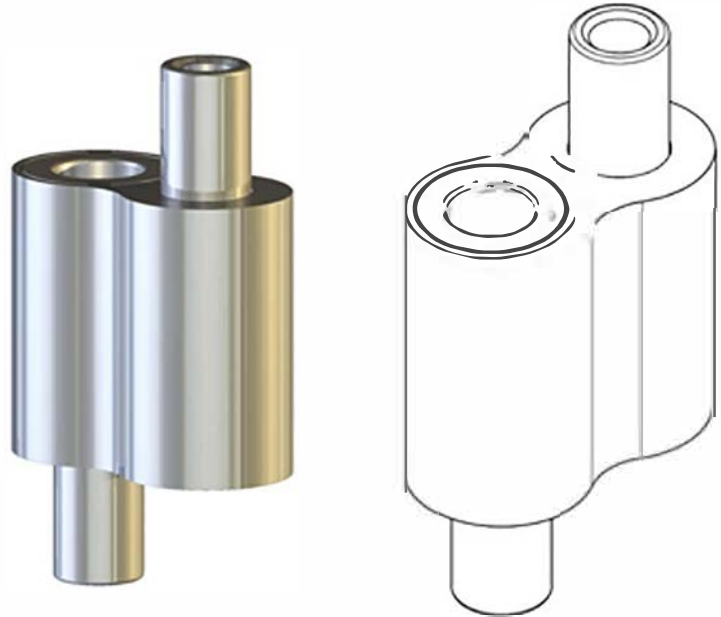

AIRCRAFT CABLE SUSPENSION

