



## INSTALLATION AND OPERATING INSTRUCTIONS

# 12EBL - 1200 Lumen Emergency Ballast

**\*WHEN ORDERED AS A FIXTURE OPTION, THE 12EBL COMES PRE-INSTALLED INSIDE THE FIXTURE\***

## INSTALLATION

Product includes the following components:

PARTS	QUANTITY
LED Emergency Driver & Battery (including Test Button)	1
Emergency LED Module	1
Hardware (Tek Screws)	6
Luminaire Modification Label	1

**Note:** Install requires application of the Luminaire Modification Label provided in your Kit, as per UL. This label includes the statement: "This equipment has more than one power supply connection point." This label must be applied to the fixture housing during installation.

## IMPORTANT SAFEGUARDS

When using electrical equipment, basic safety precautions should always be followed including:

### READ AND FOLLOW ALL SAFETY INSTRUCTIONS

**WARNING:** Risk of fire or electric shock. Luminaire wiring and electrical parts may be damaged when drilling for installation of LED Emergency Backup. Check for enclosed wiring and components.

**WARNING:** Risk of fire or electric shock. This LED Emergency Backup installation requires knowledge of luminaires electrical systems. If not qualified, do not attempt installation. Contact a qualified electrician.

**WARNING:** Risk of fire or electric shock LED Emergency Backup is only for use in surface mount or recessed Type IC or Non-IC luminaires listed to UL Standards. Suitable for use in damp locations and plenum spaces. Not for use in heated air outlets or hazardous locations.

**WARNING:** Risk of fire or electric shock. Do not alter, relocate, or remove wiring, lampholders, power supply, or any other electrical component.

**WARNING:** To prevent wiring damage or abrasion, do not expose wiring to edges of sheet metal or other sharp objects.

**WARNING:** Do not make or alter any open holes of the wiring enclosure or electrical component enclosure during installation. Only those open holes indicated in the instructions and/or drawings may be added or altered as a result of LED Emergency Backup installation. Do not leave any other open holes in the wiring enclosure or electrical component enclosure during installation.

**CAUTION:** Before installing, make certain the AC power to the fixture is off.

**CAUTION:** The electrical rating of this product is 120-277V. Installer must confirm that there is 120- 277V at the fixture before installation.

**CAUTION:** LEDs are extremely bright. Do not look directly at the LED light source for extended time as over-exposure may cause harm to the eyes.

**CAUTION:** Verify that all replacement lamp types marked on the installed luminaire are also identified as suitable for use with this emergency battery pack.

The emergency LED driver shall be enclosed by the LED luminaire and bonded to the grounding of the LED luminaire.

Do not use outdoors.

Do not let power supply cords touch hot surfaces.

Do not mount near gas or electric heaters.

Use caution when servicing batteries. Battery acid can cause burns to skin and eyes. If acid is spilled on skin or in eyes, flush acid with fresh water and contact a physician immediately.

Equipment should be mounted in locations and at heights where it will not readily be subjected to tampering by unauthorized personnel.

The use of accessory equipment not recommended by the manufacturer may cause an unsafe condition.

Do not use this equipment for other than its intended use.

## SAVE THESE INSTRUCTIONS

The retrofit assembly is accepted as a component of a luminaire where the suitability of the combination shall be determined by UL or Authorities Having Jurisdiction.

## INSTALLATION

1. Read and understand all warnings and notes stated above before proceeding with installation.
2. Check your LED Emergency Backup Kit against parts list.
3. Disconnect power to fixture.
4. Remove / Open the fixture's diffuser cover/lens (if applicable.)
5. Remove all original lamps, and ballast cover/wire way cover from the fixture.
6. Pre-drill one 1/2" hole into the fixture ballast cover/wire way cover for the test switch. See Figure 1.
7. Determine appropriate location for the Battery Backup LED Driver and LED Battery Pack in the fixture. LED Battery Pack can be remote mounted on top of the fixture if needed. If remote mounting of battery is required, drill a 1/2" hole in fixture as needed or use exiting fixture knockout to run battery wires through. Before drilling, ensure drill bit will not interfere with any exposed wiring above fixture. Deburr edges of new hole and/or use a grommet to prevent sharp edges from damaging wires.
8. Install the Battery Backup LED Driver and LED Battery Pack to the fixture using (4) 8-18x1/2" Philips Pan Head Self-Drilling Tek Screws. Use existing mounting holes in fixture or make new holes as needed.
9. Determine appropriate location for the Emergency LED Module on the fixture, to provide maximum delivered light downward. LED Module should not be located directly behind any metal work or existing lamps the fixture is using. See Figure 2.
10. Install the Emergency LED Module to the fixture using (2) 8-18x1/2" Philips Pan Head Self-Drilling Tek Screws.
11. Insert Test Switch into the pre-drilled hole in the fixture's wire way cover. See Figure 3.
12. Complete wiring as indicated. Ensure hot/live lead going to the black wire on the Emergency LED driver is un-switched. See Figures 4 and 5.
13. Ensure Emergency LED Module comes on once Battery connection is made.
14. Ensure all input wires are passed through the fixture's access plate.
15. Re-install the ballast cover / wire way cover and any original lamps as needed. See Figure 6.
16. Adhere Luminaire Modification label to the fixture on the ballast cover where it is easily visible to anyone servicing the fixture in the future.
17. Turn on AC power to the fixture and confirm Emergency LED Module turns off and original fixture light source comes back on.
18. Push test button to confirm test button is functioning properly. Original fixture light source should turn off and Emergency LED Module should illuminate.

**Note:** The 12EBL included driver was designed to be used with the LED module included in the kit.

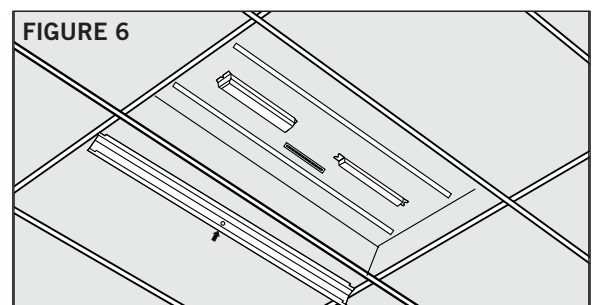
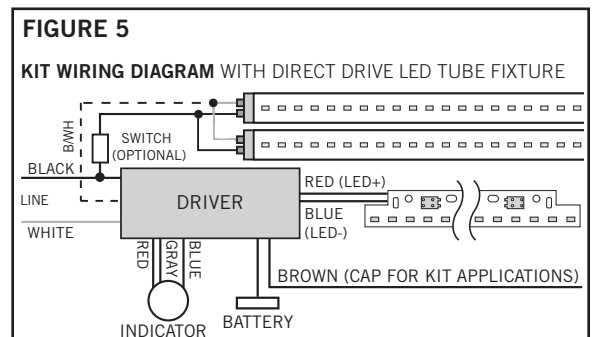
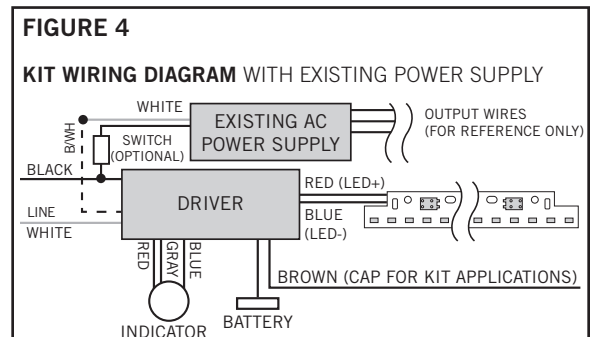
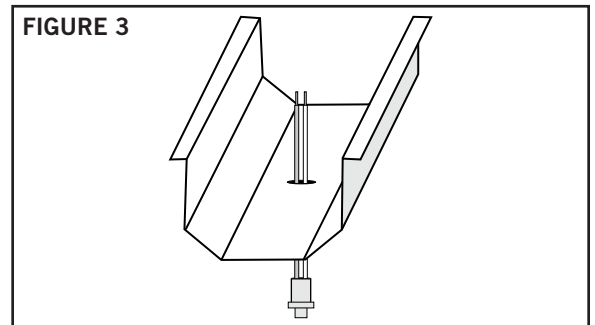
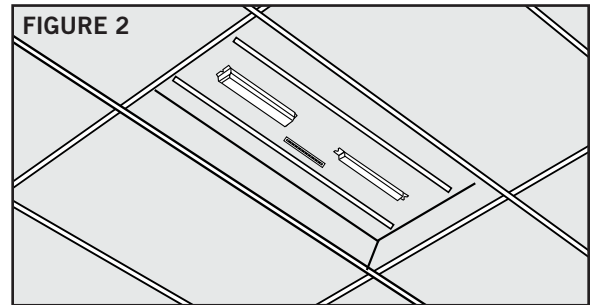
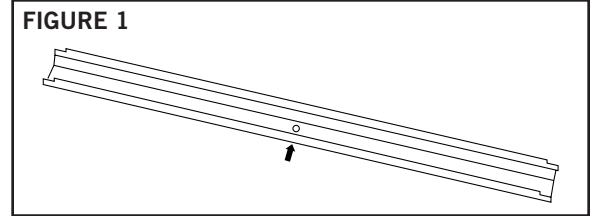

## Specification Chart

ORDER CODE	DESCRIPTION	PACKAGING STYLE	PACK QTY.	ITEM STATUS
12EBL	LED Emergency Driver Kit with Battery and 0.7" x 8" 1200 lumen LED Module	Individually Packaged	1	Active

<sup>1</sup>When operating at 0°C, rated output drops to 0.6W and 1060 lumens

### Determining Adequacy of Means-of-Egress Lighting Levels

Follow industry standards by utilizing available .ies files and lighting design software for your dedicated emergency luminaires, with the above calculated emergency lumens, and validate your as-installed plans in accordance with the applicable life safety codes governing your project.

While these products are compliant with the requirements of UL Standard 924, it is ultimately the responsibility of the designer/specifier to assure the as-installed system delivers code compliant path of egress illumination in accordance with federal, state or local municipal requirements.

### Operation

Normal Mode: AC power is present. The AC driver operates the LED load as designed. The emergency pack is charging in a standby mode. The test button will be lit, showing that the battery is charging.

Emergency Mode: When the AC power goes out, the emergency pack detects the power outage and automatically switches to the emergency mode. The LED load is illuminated for a minimum of 90 minutes. When AC power is restored, the emergency pack switches back to Normal Mode and starts re-charging.

### Testing Procedures

Press the test button to cut the power to the AC driver and switch the system to emergency mode. Release the test button to return to normal mode. Switch off the circuit breaker to simulate a full power outage. For Initial Testing, allow the unit to charge approximately 1 hour, then conduct a short discharge test. Allow a 24 hour charge before conducting a one hour test.

NFPA 101, Life Safety Code outlines the following schedule:

Monthly - Insure that the test button light is illuminated. Conduct a 30 second discharge test by depressing the test button. The LED load should operate at reduced output.

Annually - Insure that the test button is illuminated. Conduct a full 90 minute discharge test. The unit should operate as intended for the duration of the test.

“Written records of the testing shall be kept by the owner for inspection by the authority having jurisdiction.”