

LHBA

LED Full Body High Bay



DESCRIPTION

The LHBA is an LED full body high bay that is a true Made In America high bay fixture. Engineered, Manufactured, and Assembled in Fort Worth, TX, the LHBA is a quality and economical made in America solution for commercial lighting needs. Perfect for applications such as garages, warehouses, gyms, manufacturing space, and large retail spaces. With an enclosed power Supply and covered optics, these light fixtures are designed for durability in commercial or industrial applications. They are designed to be stylish BAA compliant high bay fixtures that save energy and lower maintenance costs, while having an extremely high efficacy.

CONSTRUCTION

The LHBA is constructed from heavy gauge steel. If other options are needed, consult with factory. For aluminum housing, select ALH under options.

OPTICAL SYSTEM

Frosted lens with professional light distribution technique used to achieve a light transmission rate of over 90%.

ELECTRICAL SYSTEM

0-10V 1% dimming drivers are standard for 120/277V Applications. Step-Down transformers are required for 347-480V Applications. Long-life LED system rated for >130K life hours (L70 @ 25°C). Metal gear tray for internal LED driver. Complies with federal energy efficiency standards.

LISTINGS

Fixtures are IC rated for contact with insulation and can be installed in damp locations. DLC listed.

FINISH

High gloss, electrostatically applied, white powder coat finish, average minimum reflectance 92%

LED

80 CRI or 90 CRI LEDs available in 2700K, 3000K, 3500K, 4000K and 5000K. Life is >130,000 hours at 70% lumen maintenance.

WARRANTY

5 - Year Limited Warranty. Complete warranty and terms located at: www.aelnow.com/warranty

ORDERING INFORMATION

Example: LHBA4L-50-M

SERIES		CCT		VOLTAGE		DRIVER		OPTIONS	
LHBA2	1x2, 87W	27	2700K	M	120-277	BLANK	0-10V 1% Dimming Driver (included standard)	12EBL	1200 Lumen Emergency Ballast
LHBA2M	1x2, 132W	30	3000K	480	347-480	CD5	0-10V 5% to off Dimming Driver	LHBAWG	Steel White Wire Guard
LHBA2H	1x2, 180W	35	3500K			EDN	Electronic Driver Non-Dimming	LHBAPM	Pendant Mount Kit
LHBA21H	1.5x2, 215W	40	4000K			FLDD	Fifth Light Dali, Dimming	LHBASM	Surface Mount Kit
LHBA4L	1x4, 265W	50	5000K			LDE1	Lutron Hi-lume 1% Ecosystem LED Driver with Soft-on, Fade-to-black dimming technology	OC4EX	Occupancy Sensor
LHBA4M	1x4, 320W					LDE5	Lutron LDE5 5-Series Ecosystem 5% Dimming	AC10	100" Aircraft Adjustable Cable
LHBA41H	1.5x4, 425W							VDO	Lutron Vive Integral fixture controller (RF daylight & occupancy sensing)
								FCJS0	Lutron Vive Attached RF controller for 0-10V Drivers
								ALH	Aluminum Housing

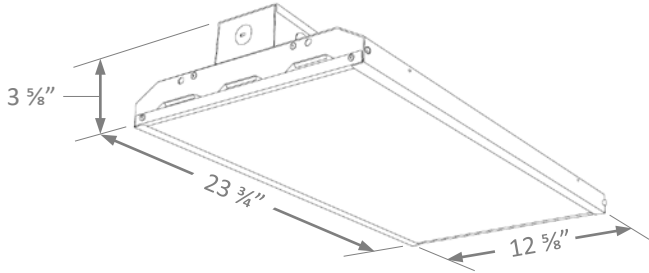
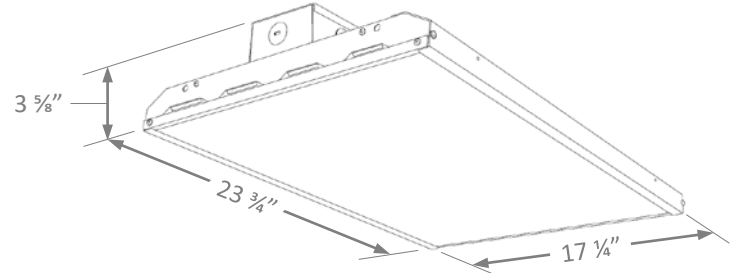
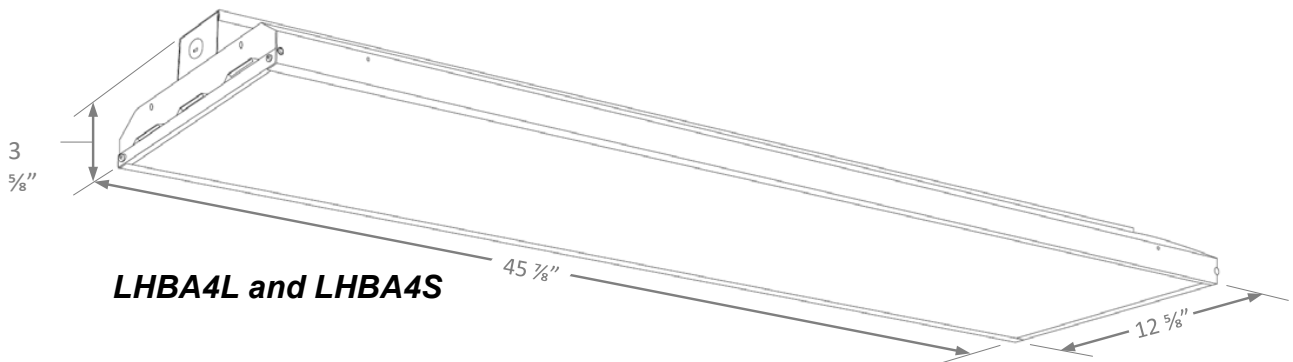
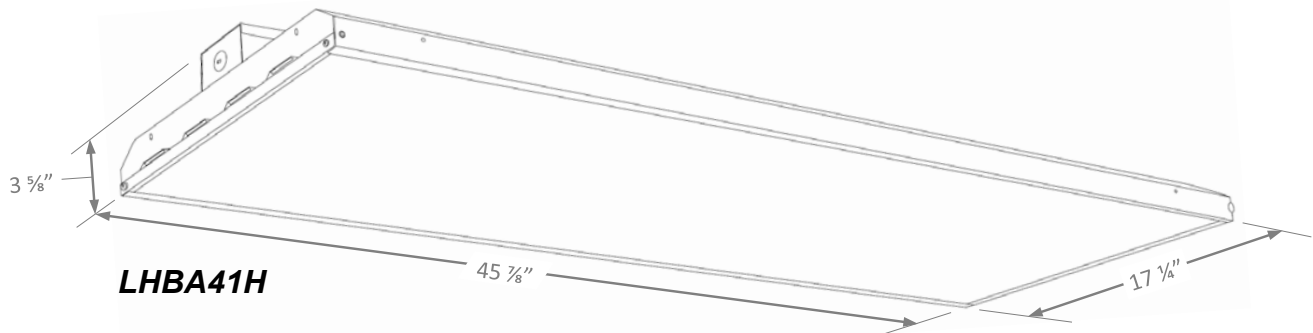
FIXTURE DIMENSIONS

LHBA2, LHBA2M, LHBA2H

LHBA21H

LHBA4L and LHBA4S

LHBA41H
ENERGY AND PERFORMANCE DATA

Input Voltage	120/277VAC
System Input Power	87 - 428 Watts
Delivered Lumen Output	12394 - 60629 Lumens
Standard Dimming Control	0-10V
CCT	2700, 3000, 3500, 4000, 5000 Kelvin
CRI	82 (minimum)
Life Time Rating	>130,000 hrs @ L70
Input Frequency	50/60 Hz
Power Factor	>0.9
Operating Temp	30° to 50° C

*Actual wattage may differ by ±5% while operating 120/277V ±10%

LED SYSTEM DATA			
SERIES	SIZE	WATTAGE	LUMENS
LHBA2	1x2	87W	12394lm
LHBA2M	1x2	132W	18564lm
LHBA2H	1x2	180W	25298lm
LHBA21H	1.5x2	213W	30356lm
LHBA4L	1x4	267W	37996lm
LHBA4M	1x4	320W	44460lm
LHBA41H	1.5x4	428W	60629lm